



BANDRASTER

SUSPENSION SYSTEM



NCS Bandraster is a super heavy duty metal suspension system which accommodates custom lay-in metal ceiling panels. It's ideal for very large spaces, like airports, shopping centres and malls.

APPLICATIONS:

- Shopping centres
- Airports
- Large retail spaces

SHORT SPECIFICATION

Ceiling shall comprise custom metal ceiling panels with NCS Bandraster exposed grid system including wall trim as manufactured for NCS.

Panels shall be powder coated [specify colour], nominal size 1200 × 600 × 16mm, aligned edge detail.

TECHNICAL INFORMATION

PUNCHED BANDRASTER PROFILE

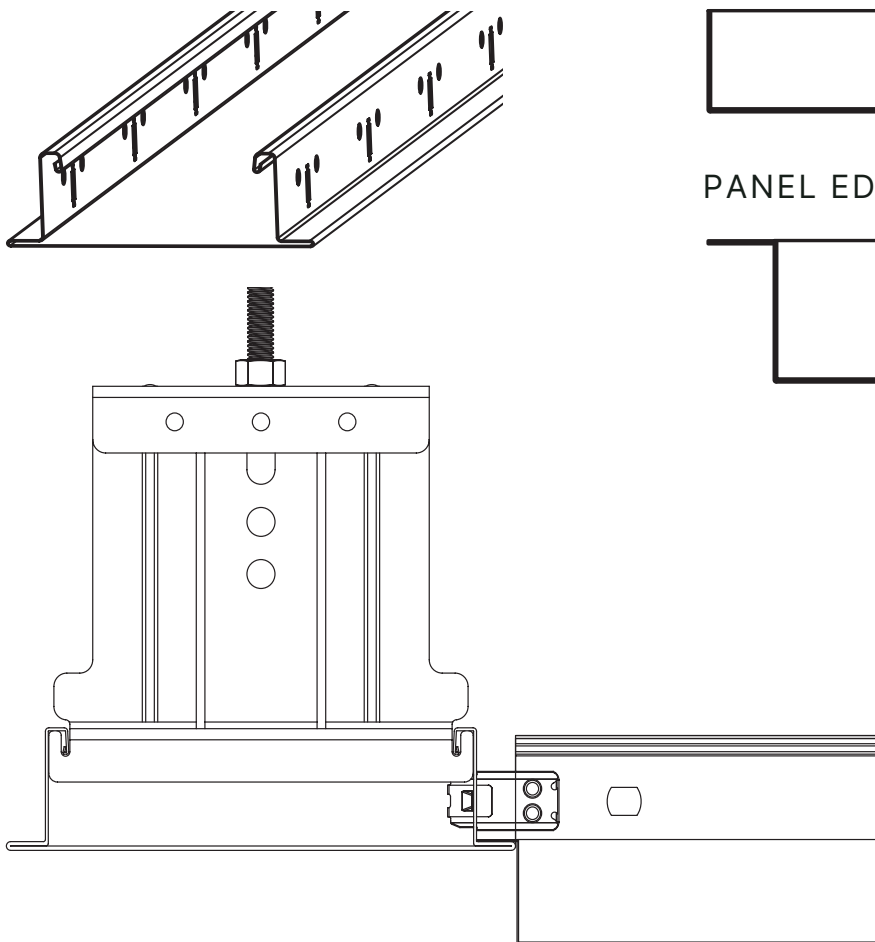

PANEL EDGE PROFILE - ALIGNED



PANEL EDGE PROFILE - LOWERED

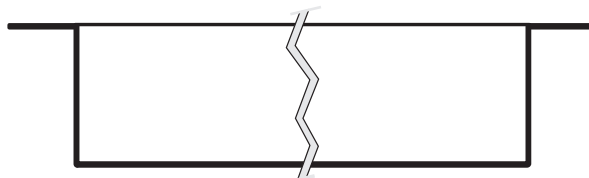

WEIGHT

Varies

ENVIRONMENTAL LIMITATIONS

90% Relative Humidity (RH).

CORROSION RESISTANCE

Galvanised steel: C2 Class

Pre-painted galvanised steel: C3 Class

Post-painted galvanised steel: C4 Class

Pre & post-painted aluminium: C5 Class

FLEXION RESISTANCE

Maximum span 1200mm - 1 Class

FIRE REACTION

Structure, suspensions and wall angles: A1 Class

Smooth or perforated panels with high acoustic fleece: A1 Class

Perforated panels with standard acoustic fleece: A2S1D0 Class

INSTALLATION

Do not begin installing until the building is fully enclosed, dry and watertight; and suitable permanent heating and cooling equipment is in operation.

STORAGE

Materials must be stored in a closed, clean and dry site, out of direct sunlight. Handle packages with care to avoid damage.

CLEANING RECOMMENDATIONS

To clean, use a wet cloth with warm water and neutral non-abrasive detergents.

AXONOMETRIC DIAGRAM

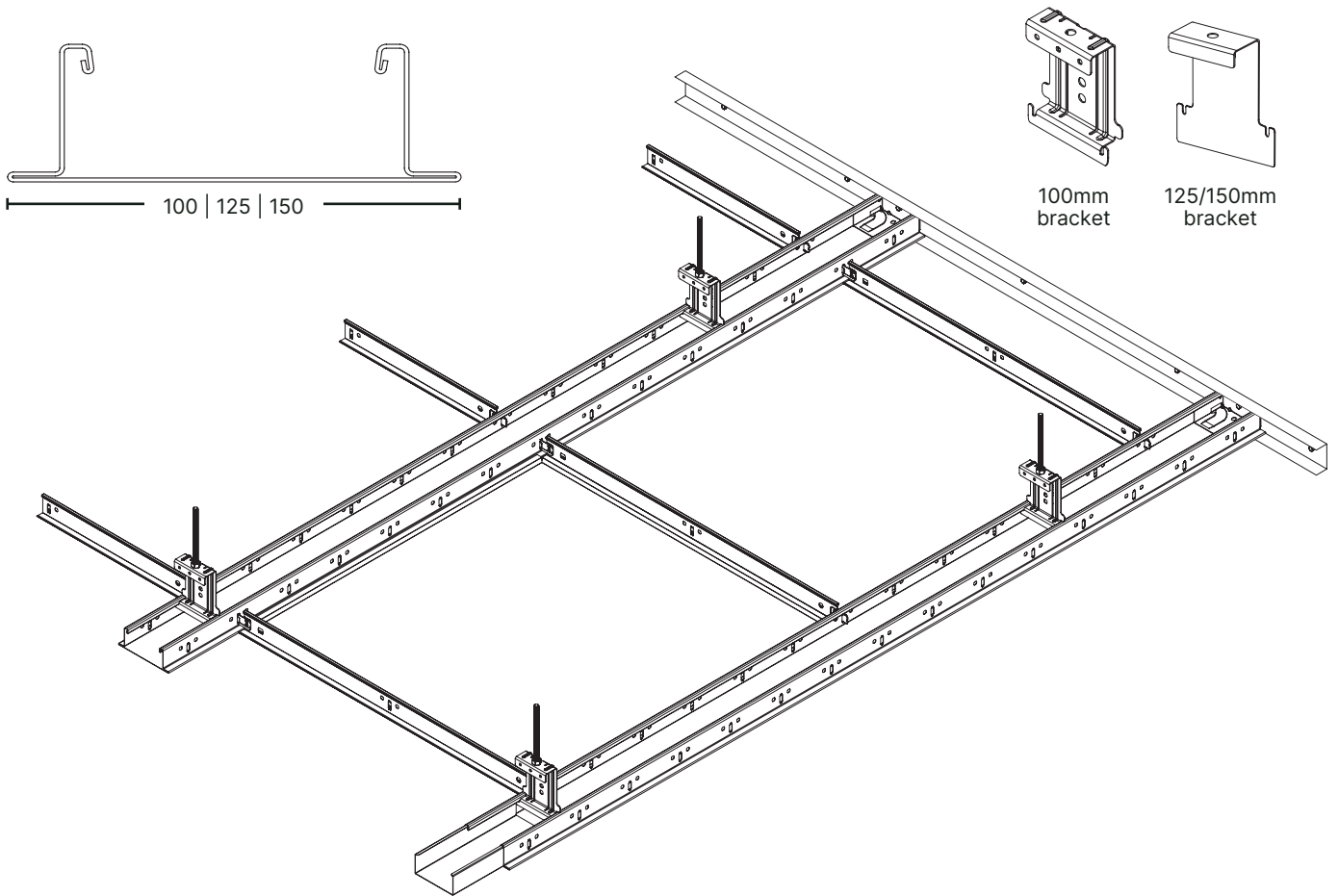

HANGER OPTIONS

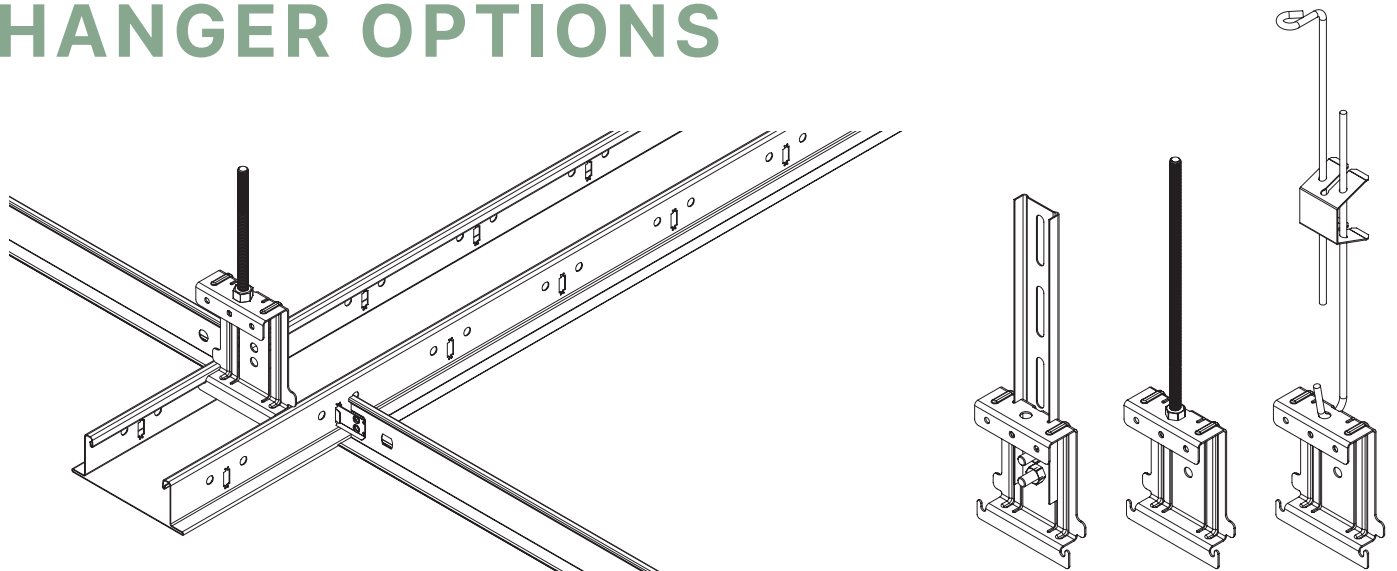

INSTALLATION

1. Set out ceiling levels with a level or stringline. Install wall angle to perimeter of ceiling.
2. Fix threaded bar to substrate.
3. Insert hanging bracket on Bandraster profiles and attach profiles to threaded bar.
4. Insert cross-tee profiles into the punches in the Bandraster profiles.
5. Lay ceiling panels.

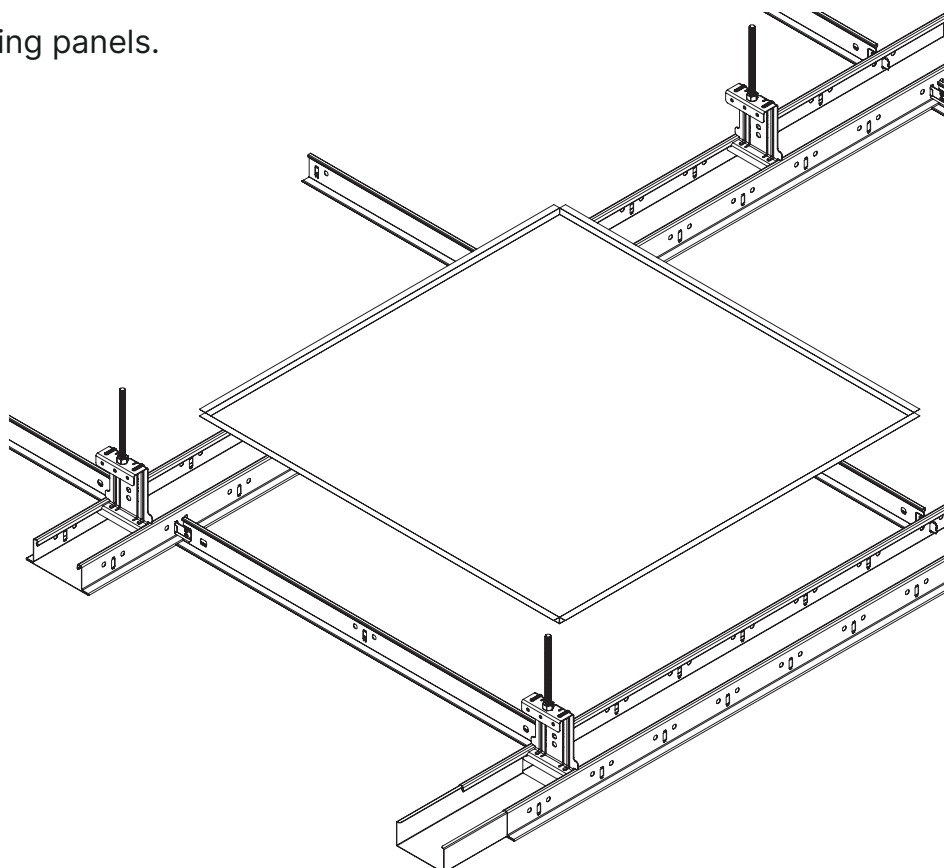

BRACKET ASSEMBLY

